

Mechanical:

REV.	ECN NO.	DESCRIPTION	DATE	APPD
A	REL		2015-04-21	

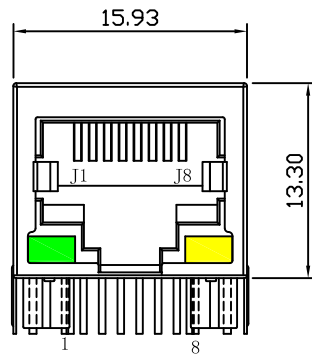

Front Side View

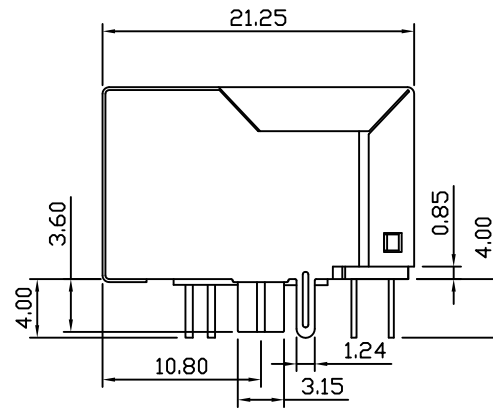

Left Side View

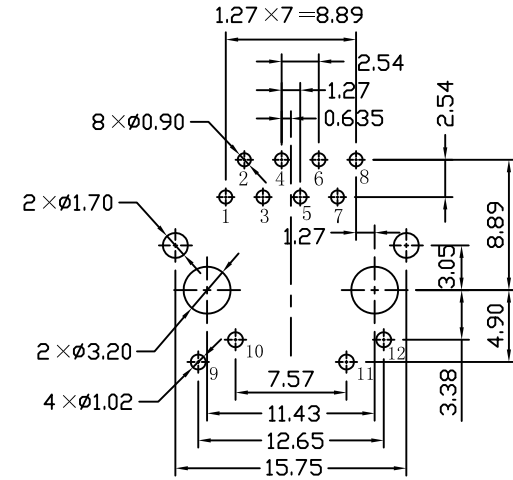

Suggested PCB Layout

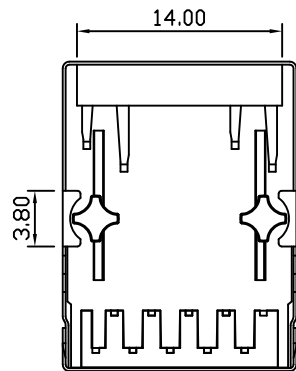

Bottom Side View



Top Side View



NOTES:

1. Meets IEEE 802.3 specification
2. Connector Materials:

Housing Material: Thermoplastic PBT+30%G.F UL94V-0

Contact Material: Phosphor Bronze C5210R-EH Thickness=0.35mm

Pins: Brass C2680R-H Thickness=0.35mm

Shield: SUS 201-1/2H Thickness=0.2mm

Contact plating: Gold 6 micro-inches min. In contact area.

3. Wave solder tip temperature: 265°C Max, 5 Sec Max
4. UL Certification: File Number E321120

X:X ±0.25	APPD:	Trxcom Huizhou Trxcom Electronics Co.,Ltd.
X:XX ±0.20	CHKD:	
X:XXX ±0.05	DR: GRANT	TITLE: RJ45 Connector with 10/100 Base-T Integrated Magnetics
ANGLES ±1°	UNIT: mm	PART NO.: TRJ0011BBNL
	SCALE: 2/1	SHEET: 1/4
	REV: A	DWG NO.: TRC13122717